



**Kirk Key Interlock Company**

211 Wetmore Ave. S.E., Massillon, OH 44646

Phone: 330.833.8223 • Fax: 330.833.1528 • Toll Free: 800.438.2442

Email: sales@kirkkey.com

**www.kirkkey.com    Type CN22 - Threaded Cylinder Mounting**

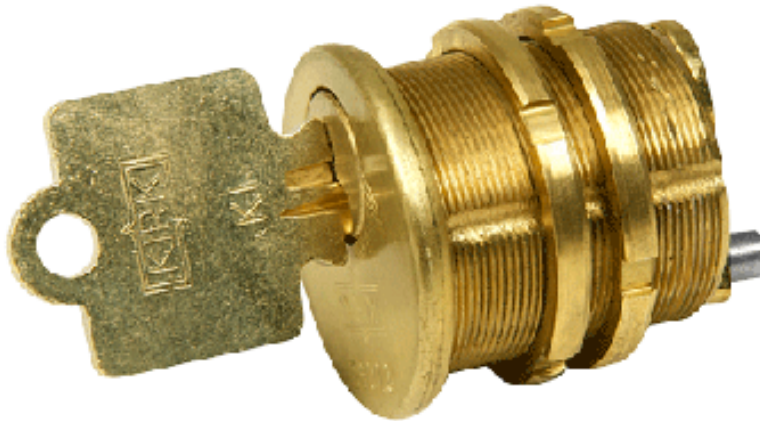

The Type CN22 is a threaded cylinder interlock, commonly installed on circuit breaker interlocking kits. The cam on the back of the cylinder is made to interact with existing linkage on your equipment. The key is trapped or released according to the position of the cam. The CN22 can be linked to other CN22s with the proper bracketry.

Because the CN22 does not have a housing, it is designed to be installed on provisions or bracketry supplied by the breaker manufacturer. Each CN22 comes with two locknuts (as pictured).

The cylinder body and cam are made of brass and the cylinder face is made of polished nickel, or polished brass.

The supplied cam can be removed and replaced with your own to interact with special linkages on your equipment.

**OPTIONS**

- Stamp Key Interchange - specify an alphanumeric code to be stamped on the cylinder face and the key (e.g. A1, A2, B1, etc. - up to 5 characters). See SD Series Data Sheet for Keys (3.4) and Terminology (4.1) for details.

**\*\*\* IMPORTANT NOTE \*\*\***

BEFORE REMOVING THE CAM, PLEASE BE SURE THAT THE KEY IS REMOVED FROM THE LOCK. THIS ENSURES THAT THE PLUG DOES NOT SLIDE OUT, RELEASING ALL OF THE DRIVERS AND PINS OF THE LOCK.

**\*\*\* IMPORTANT NOTE \*\*\***

# SD SERIES - SPECIFICATION DATA SHEET 1.10



## Kirk Key Interlock Company

211 Wetmore Ave. S.E., Massillon, OH 44646

Phone: 330.833.8223 • Fax: 330.833.1528 • Toll Free: 800.438.2442

Email: sales@kirkkey.com

## www.kirkkey.com Type CN22 - Threaded Cylinder Mounting

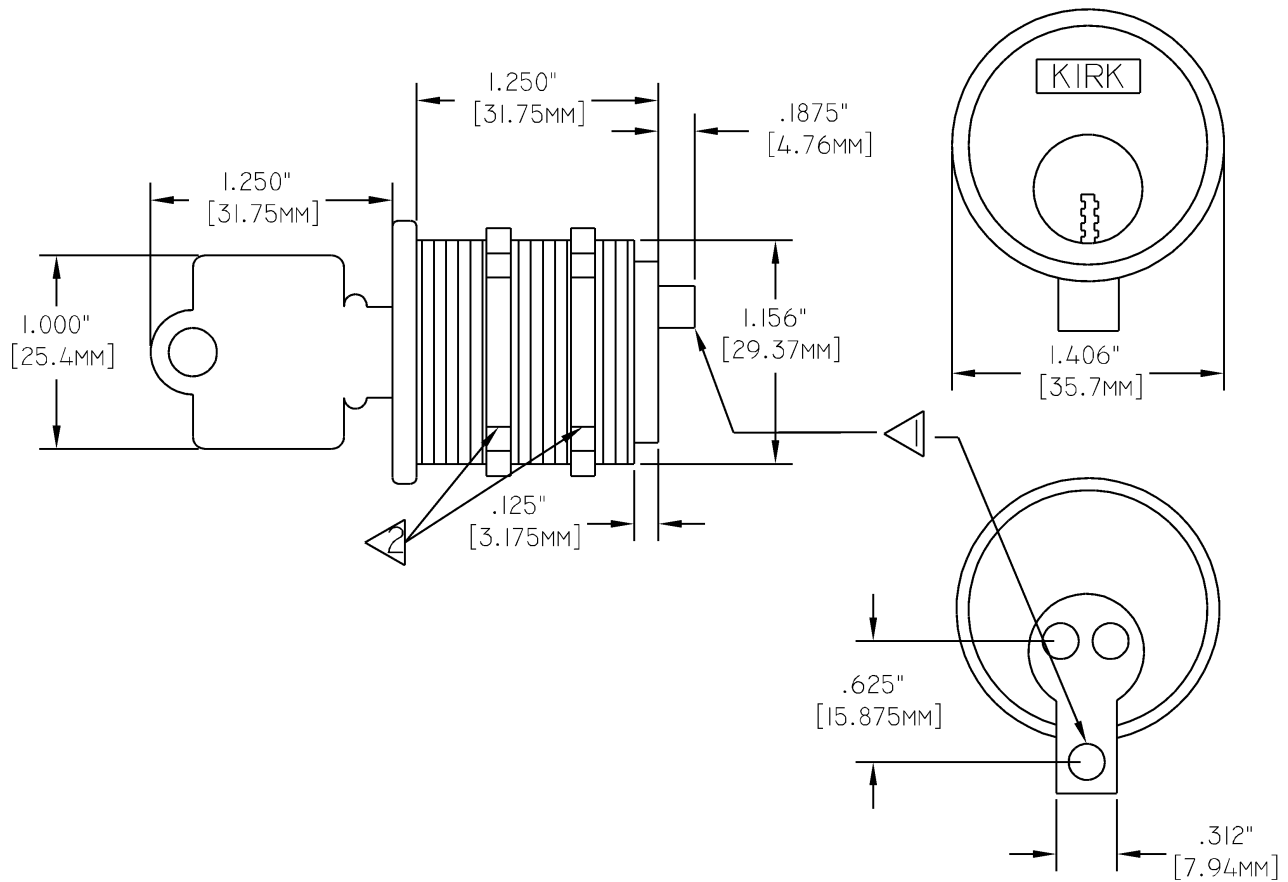

### NOTES:

- 1) 3/16" (4.76mm) diameter pin.
- 2) Two locking nuts provided.