

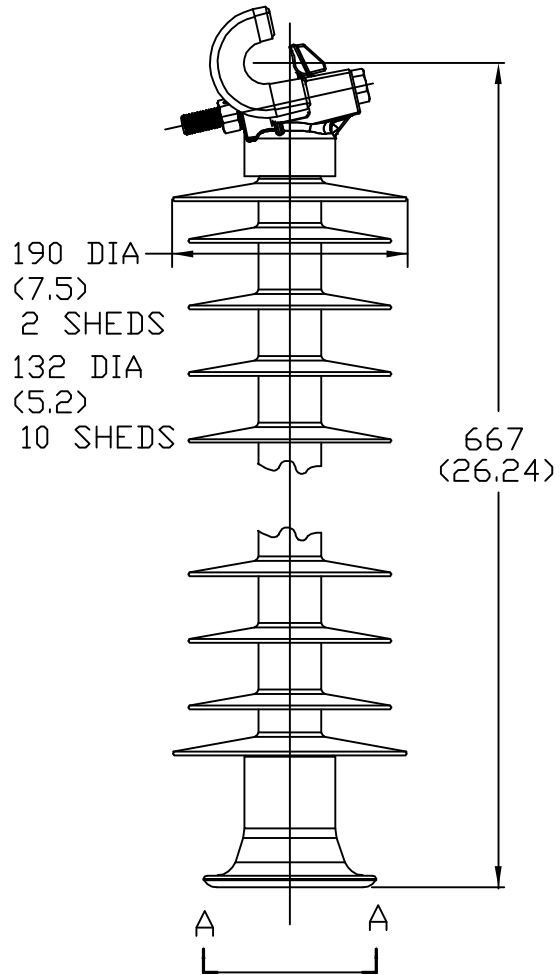

VIEW A-A
2X SCALE



DRY ARCING DISTANCE	_____	566 MM (22.3 IN)
LEAKAGE DISTANCE	_____	1478 MM (58.2 IN)
60 Hz DRY FLASHOVER	_____	230 kV
60 Hz WET FLASHOVER	_____	180 kV
IMPULSE POS. CRITICAL: FLASHOVER	_____	360 kV
IMPULSE POS. WITHSTAND	_____	330 kV
SCL	_____	11 kN (2470 LB.)
RCL	_____	5.5 kN (1235 LB.)
NET WEIGHT	_____	7.2 KG (15.9 LB.)

<p>CONFIDENTIAL: THIS DRAWING AND ITS CONTENTS ARE CONFIDENTIAL AND THE EXCLUSIVE PROPERTY OF HUBBELL POWER SYSTEMS. NO PUBLICATION, DISTRIBUTION OR COPIES MAY BE MADE WITHOUT THE WRITTEN CONSENT OF HUBBELL POWER SYSTEMS. HUBBELL POWER SYSTEMS UNPUBLISHED ALL RIGHTS RESERVED UNDER THE COPYRIGHT LAWS.</p>			HUBBELL® POWER SYSTEMS	
	TITLE VERI LITE 69 KV LINE POST			
SIZE S	DWG NO. --	CAT / PART / ASSY NO. 80S069-0K09	REV 0	
DO NOT SCALE THIS DRAWING		DRN BY JVR	DATE 06/13/13	SHEET 1 OF 1

REV DATE 06/13/13